



# GENUINE ACCESSORIES INSTALLATION INSTRUCTIONS

550-0640 Rev. AAA

**PART NUMBER:**

0000 8C P14 (DIO)/ 0000 89 P25 (PIO)

**APPLICABLE MODELS:**

2016 &gt; CX-3/Mazda 2

**REQUIRED COMPONENTS:**

ITEM	QTY	DESCRIPTION	Usage Chart	Service Part Number
------	-----	-------------	-------------	---------------------

**MIRROR ASSEMBLY:**

1	1	Mirror Assembly w/ Compass	①	0000 8C L10
---	---	----------------------------	---	-------------

**INSTALLATION KIT:**

2	1	SA Harness - 2 Conductor	①	0000 8C P25
3	10	Wire Ties	⑧	
4	1	Wire Cover	①	
5	1	A-Pillar Tether Clip (D09W-68162)	①	
6	3	Foam Tape	①	
7	3	Electro-Tap(wire connector)	②	
8	1	User Guide	①	
9	1*	Installation Instructions-English	①	
10	1*	Installation Instructions-French	①	N/A
11	1*	Installation Instructions-Spanish	①	N/A

\*Installation Instructions not included in 0000 89 P25 OR 0000 8C P25.

\*\*Installation kit may have more components than necessary. Please refer to the chart above and the instructions for required components.

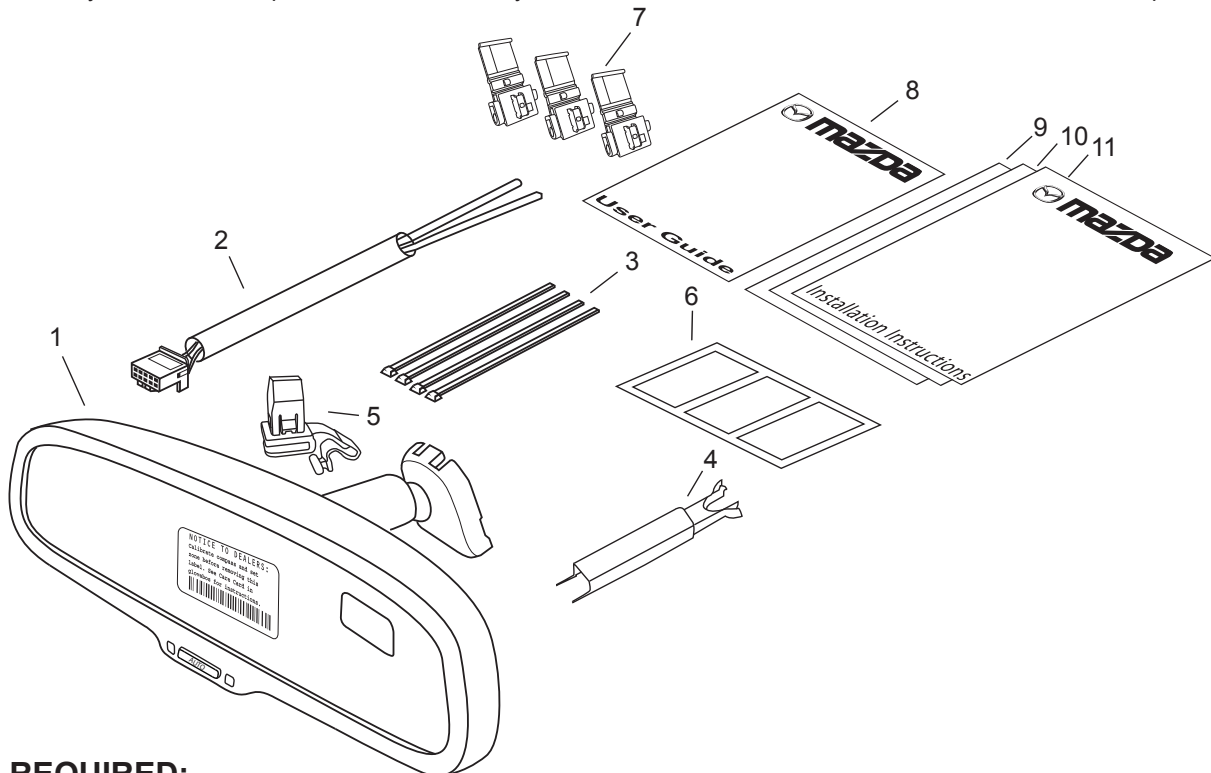
**TOOLS REQUIRED:**

HOMELINK® AND THE HOMELINK HOUSE® ARE REGISTERED TRADEMARKS OF GENTEX CORPORATION.

10mm Socket

Ratchet

Fiberstick

Needle Nose Pliers

4mm Flat Screwdriver

#T20 Torx Driver

Wire Cutters

Pliers

Clean Rag

## WIRE CODES

Two-color wires are indicated by a two-letter symbol. The first indicates the base color of the wire, the second indicates the color of the stripe. For example:

W/R = White wire with a red stripe

BR/Y = Brown wire with a yellow stripe

Symbol (Example):

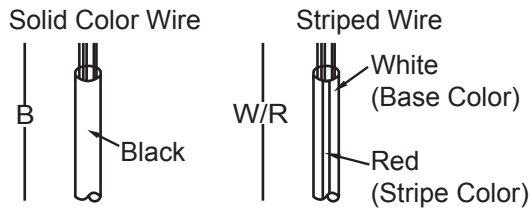

## CONNECTOR DIAGRAMS

Connector diagrams show connectors on the harness side. The terminal indicates the view from the harness side.

Example:

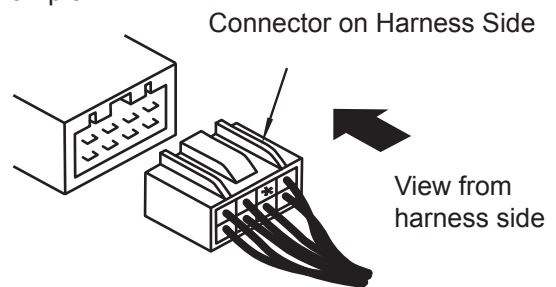

Unused terminals are indicated by "\*"

## DISCONNECTING CONNECTORS

When disconnecting the wires, grasp the connectors, not the wires.

Example:

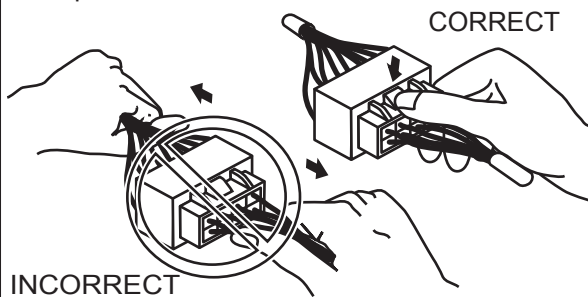

## LOCKING CONNECTORS

When locking connectors, listen for a click, indicating they are securely locked.

Example:



## WIRE TIE PROCEDURE

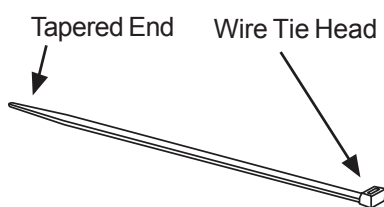

Wrap wire tie around the harness you wish to secure together.

Insert the Tapered End of the wire tie into the Wire Tie Head.

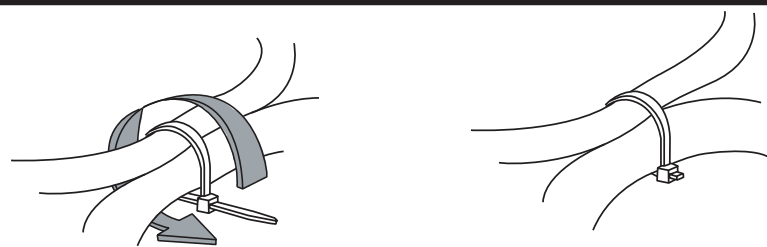

Pull the Tapered End through the Wire Tie Head until the wire tie is snug.

Trim wire tie end after tightening.

## IDC WIRE TAP PROCEDURE

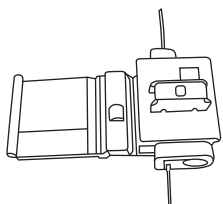

Place IDC on Vehicle Wire.

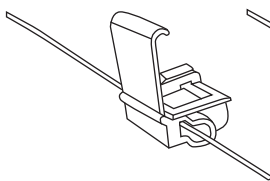

Close side of IDC.

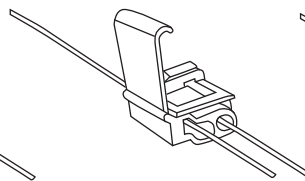

Insert EC Mirror Harness wire into IDC.

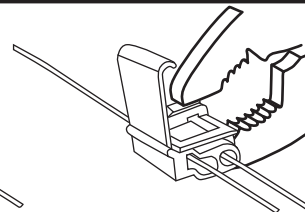

Crimp IDC metal tab over both wires until flush with top of IDC.

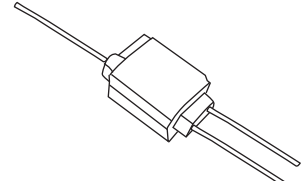

Close top of IDC.

## INSTALLATION PRECAUTIONS / NOTES:

- If using fish wire, use caution to avoid damage to existing components.
- Do not place wire harness against objects with sharp edges that may cause electrical shorting.
- Verify that power harness path will not interfere with brake, clutch, emergency brake or air bag operation. Use wire ties to hold the wiring away from critical locations.

### 1 Preparation

1. Place kit components on a clear, padded surface and inspect for damage, defects, or missing components.
2. Record customer's programmed Radio - AM/FM/SAT stations and trip computer (if applicable).
3. Disconnect negative battery terminal.
  - a) Using 10mm socket, remove negative battery terminal. (Fig. 1-1)
4. Remove driver-side door seal.
  - a) Pull back past top of A-pillar trim. (Fig1-2)
5. Remove driver-side scuff plate.
  - a) Use fiberstick to disengage clips. (Fig. 1-3)
6. Remove driver-side kick plate.
  - a) Unscrew plastic cap.
  - b) Grasp kick plate at rear and pull out towards passenger-side of vehicle. (Fig. 1-4)

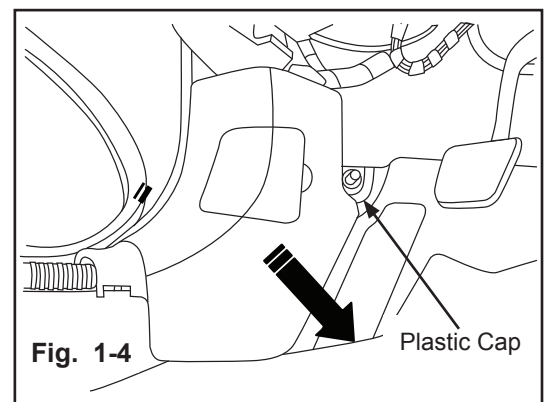
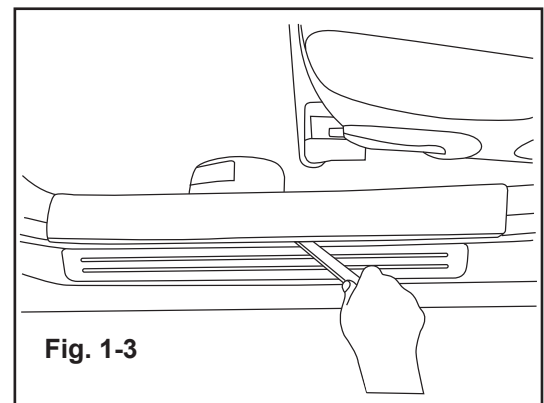
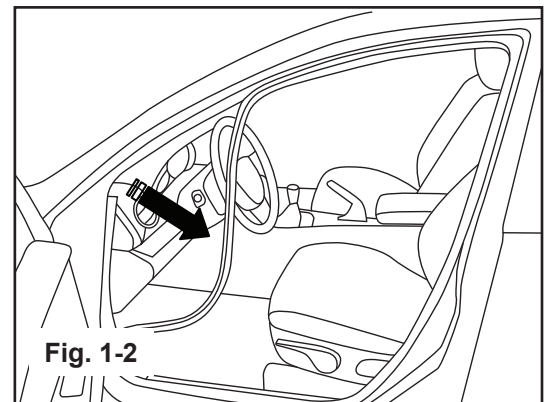
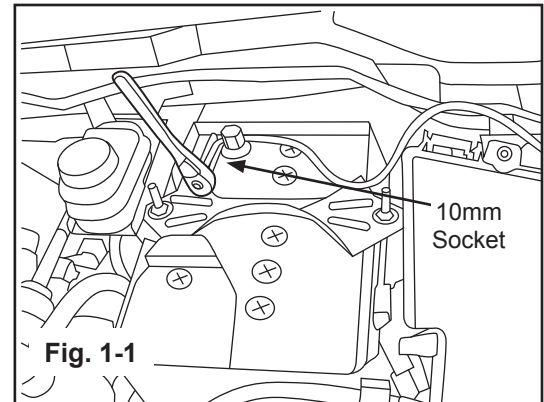

## 7. Remove driver-side A-pillar trim.

### NOTE

**Do not use excessive force. A-pillar could be damaged.**

- Pull out the top portion of A-pillar trim towards passenger-side of vehicle until A-pillar push-pin connector is extended approximately 1½". (Fig. 1-5)

### NOTE

**A-pillar connector will remain attached to vehicle body. (Fig. 1-5)**

- Remove A-pillar push-pin connector from A-pillar trim. It is recommended to use your finger to slide A-pillar push-pin up off of A-pillar trim. (Fig. 1-5)
- After A-pillar trim is detached from connector, pull firmly to detach lower clips.
- Move the hook in the direction of arrows (1) and (2) using a Flathead screwdriver and detach it from the A-pillar inner panel. (Fig. 1-6)
- Remove the grommet in the direction of the arrow (3). (Fig. 1-6)

### NOTE

**A-pillar connector must be replaced with the supplied tether clip.**

- Install new supplied A-pillar tether clip into A-pillar before proceeding. (Fig. 1-7)

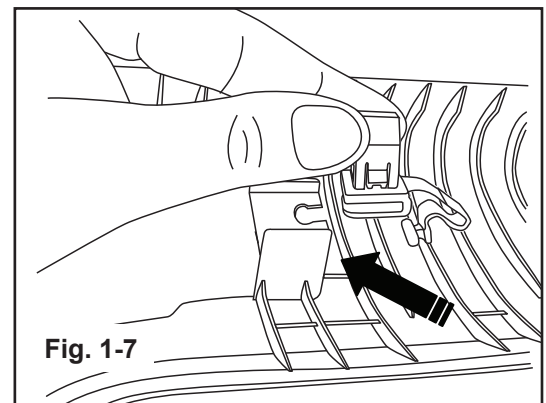
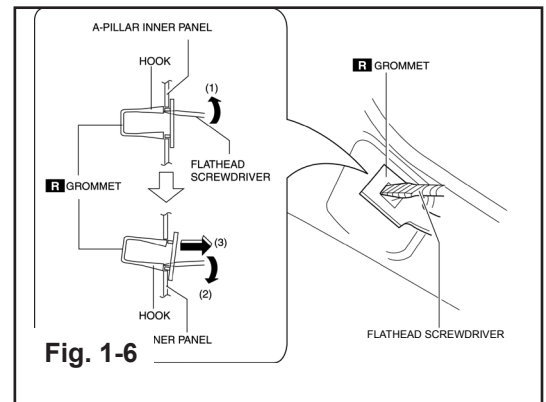
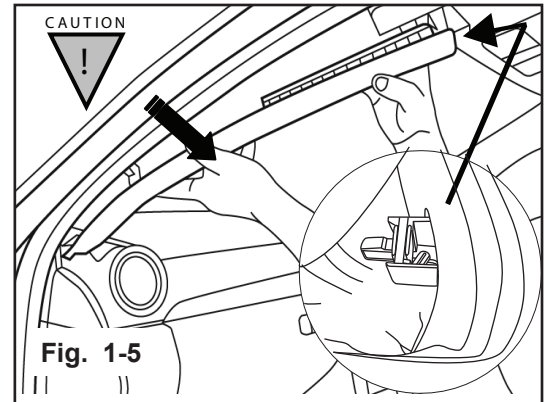

## 8. Remove OE Mirror.

- Using a #T20 Torx, loosen the mirror mounting bracket screw. (Fig. 1-8)
- Grasp mirror mount at the tube, and gently pull upwards parallel to the windshield to carefully slide mirror off windshield button.

### CAUTION

**DO NOT rotate mirror, turn mirror side to side, or pull mirror away from the windshield. Rotation, side to side movement, or pulling of mirror on windshield button could damage or break the windshield and button, requiring windshield replacement.**

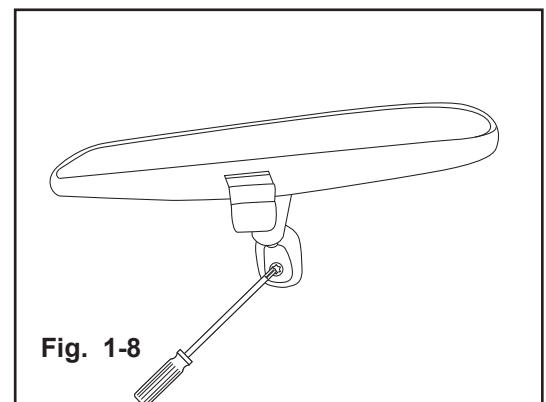

## 2 EC Mirror Installation

### 1. Attach EC mirror.

- Hold the mirror head and slide the mount downwards as far as possible over the windshield button, until fully seated. (Fig. 2-1)
- Using a #T20 Torx, tighten the mirror mounting bracket screw to 15 lb-in.

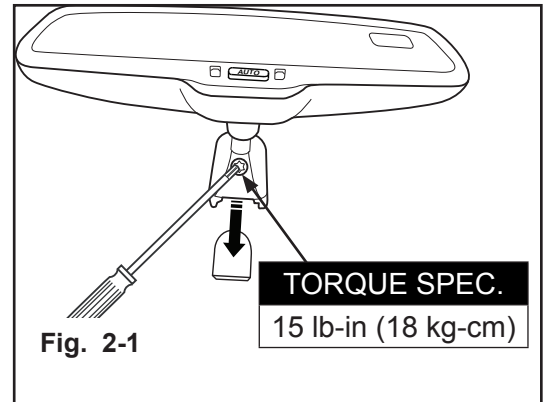

## 3 Route Mirror Harness to Vehicle Power

### 1. Plug harness connector into back of mirror. (Fig. 3-1)

- Verify connector has locked into place.

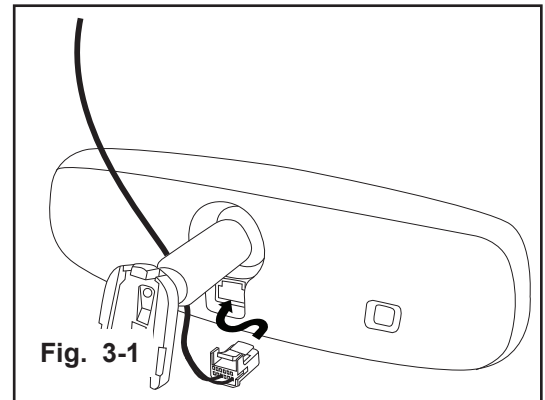

### 2. Route harness from mirror to headliner.

- Route mirror harness into groove of wire cover and attach wire cover to mirror base. (Fig. 3-2)
- Slide upper portion of wire cover up to headliner so the “forks” are held by the headliner. (Fig. 3-2)

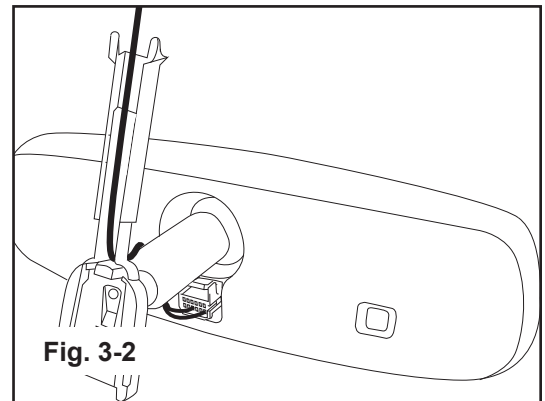

### 3. Remove sun visor clip.

- Using a taped flathead screw driver disengage locking tabs by pressing inward on both sides of the clip. (Fig. 3-3)

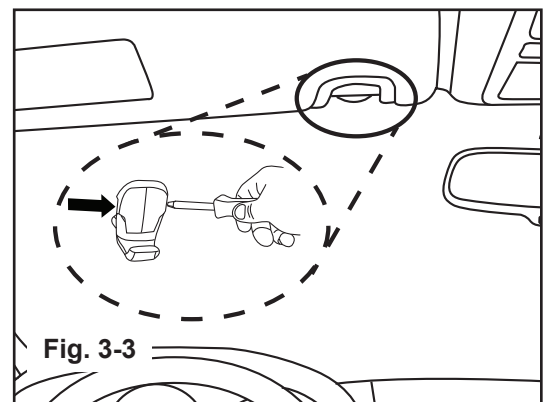

#### 4. Route mirror harness to driver-side A-pillar.

- a) Route mirror harness between vehicle headliner and roof to top of driver-side A-pillar area. (Fig. 3-4)

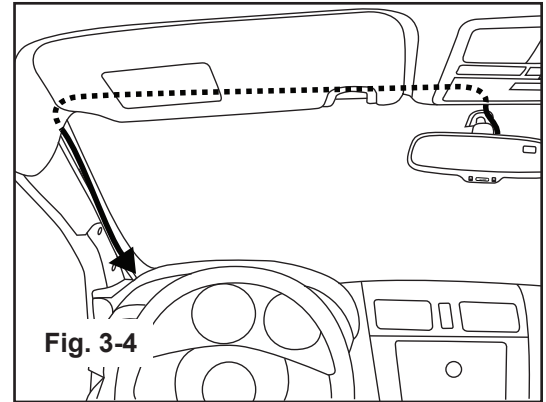

#### 5. Route mirror harness down driver-side A-pillar.

##### For vehicles with OE harness

- a) Route mirror harness down A-pillar and secure to OE harness with (6) wire ties, as shown. (Fig. 3-5)
- b) See Wire Tie Procedure on Page 2 for detailed instructions and images of proper wire tie installation techniques.

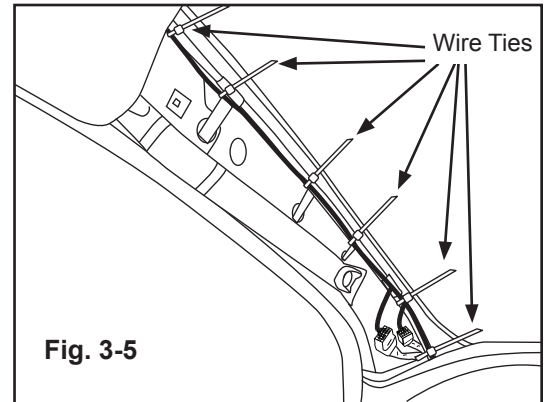

##### NOTE

**!** For vehicles without OE harness, secure mirror harness using foam tape.

##### CAUTION

**!** Ensure mirror harness does not interfere with airbag operation. Do not secure wire ties to air bag or sunroof drain tube.

#### 6. Route mirror harness through dash towards BCM.

- a) Route mirror harness through driver-side outer dash panel and into foot well area near BCM. (Fig. 3-6)

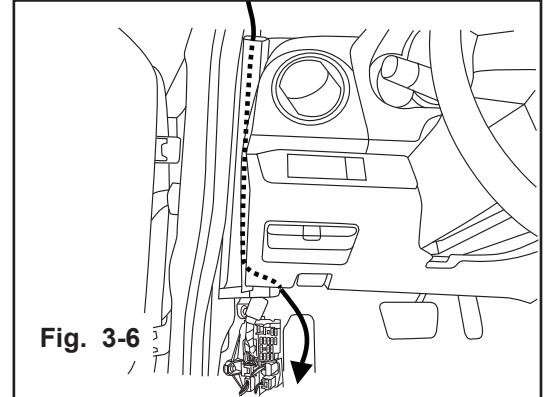

## 4 Connect EC Harness Power and Ground

### 1. Locate 8-pin connector.

- a) In the kick panel area locate 8-pin connector on the ESU plate as shown in (Fig. 4-1)
- b) Trim protective tape on the harness to expose enough wire for attaching IDC connectors.

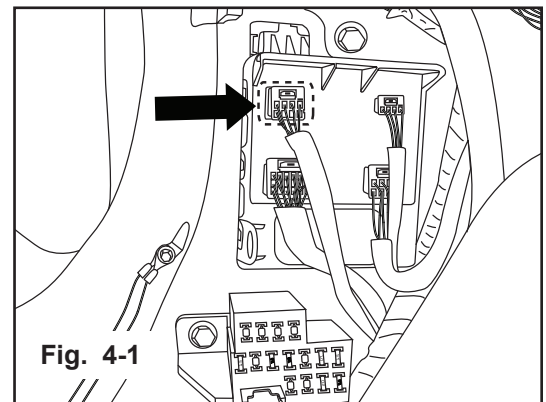

## 2. Connecto mirror Harness to +12V Ignition.

- Locate the **Light Green wire** in the location shown of the 8-pin connector. (Fig. 4-2)
- Attach IDC connector to this **Light Green wire** of the 8-pin connector.
- Insert end of **RED wire** of the mirror harness into opening of IDC connector on the **Light Green wire**. (Fig. 4-3)

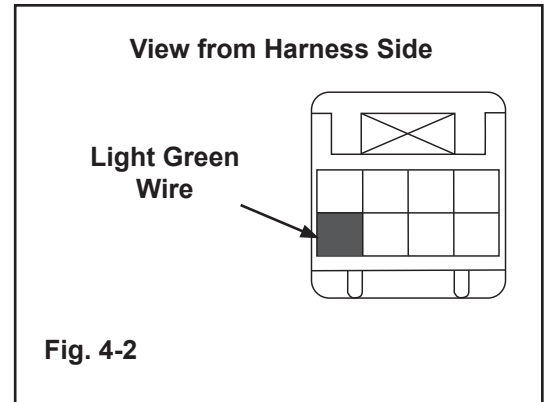

- Using Pliers, crimp IDC tab and then close plastic top.
- See **IDC Wire Tap Procedure on Page 2** for detailed instructions and images of proper wire tap installation techniques.

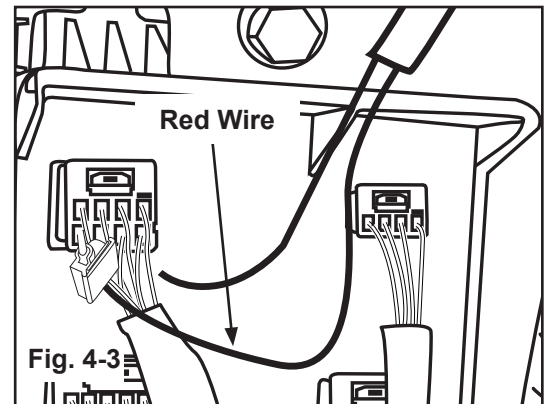

### CAUTION

Verify mirror harness path is clear of emergency brake. Route harness above brake cable.

## 3. Connect mirror harness to Ground.

- In the same 8-pin connector, locate the Black wire. (Fig. 4-4)
- Attach IDC connector to this **Black wire** of the 8-pin connector.
- Insert end of **Black wire** of the mirror harness into opening of IDC connector on the **Black wire**. (Fig. 4-5)

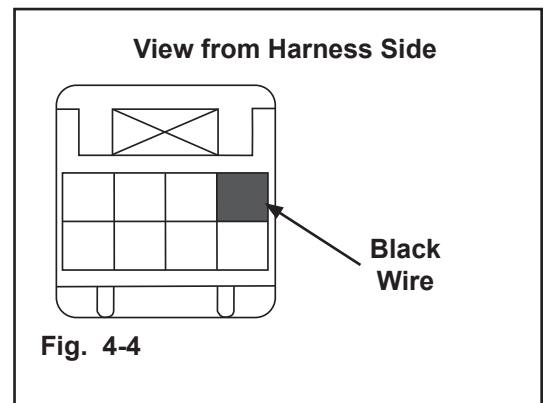

- Using Pliers, crimp IDC tab and then close plastic top. (See **IDC Wire Tap Procedure on Page 2**)

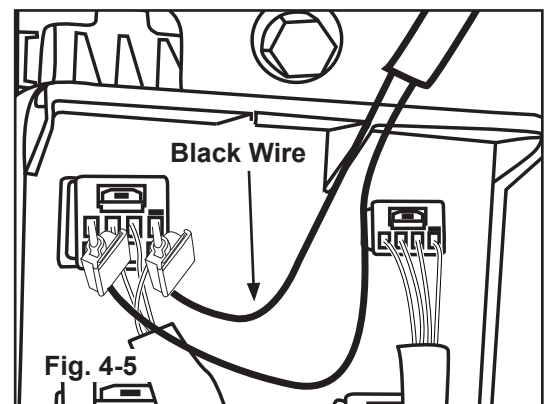

## 5 Secure Remaining Mirror Harness Wires

1. Wrap 1 foam tape around mirror harness.
  - a) Protect mirror harness by wrapping (1) foam tape on mirror harness at touch off point to the vehicle (**Fig. 5-2**).
2. Bundle excess harness wires with wire ties.
  - a) Secure remaining mirror harness to OE harness using (2) wire ties.
  - b) See **Wire Tie Procedure on Page 2** for detailed instructions and images of proper wire tie installation techniques.

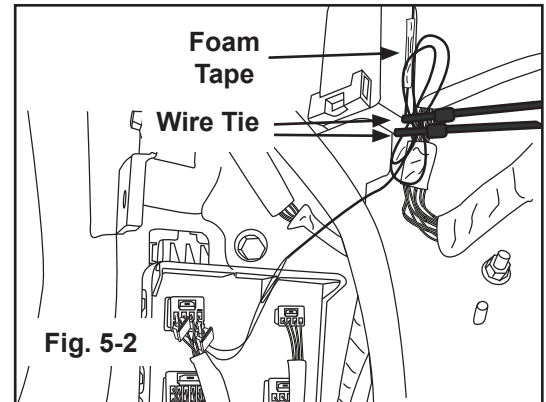

## 6 Testing

1. Reconnect negative battery cable.
2. Turn the ignition switch to ON.
3. With the vehicle in a fairly well-lit area, perform the following:
  - a) To make sure the auto-dimming feature is on, verify that the green LED to the left of the center button is on. If it is not on, push the switch button to turn the green LED on.
  - b) Cover the forward looking photocell on the back of the mirror with a dark cloth or towel. (**Fig. 6-1**)
  - c) In a few seconds, the mirror will begin to darken.

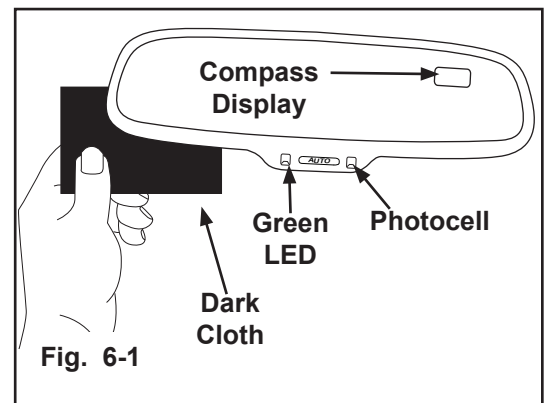

### NOTE

**Time to darken will vary with ambient light level.**

- d) Remove the cover from the forward looking photocell and the mirror will begin to clear.
- e) Verify that either a direction, such as NE, or "C" is displayed in the display window. If not, ensure the feature is turned ON by pressing the switch button.



4. Turn the ignition key to the OFF position.

**NOTE**

**!** If compass remains on, refer to troubleshooting section and recheck proper wiring installation.

5. Testing is now complete.

## 7 Installation of Removed Components

1. Trim excess off all tie wraps.
2. Reinstall in reverse order, all trim pieces removed during installation.
3. Place User Guide in vehicle glove-box. (Fig. 7-1)
4. Remove fingerprints, smudges, etc. from mirror.
5. Verify each reinstalled component for proper fit and function.

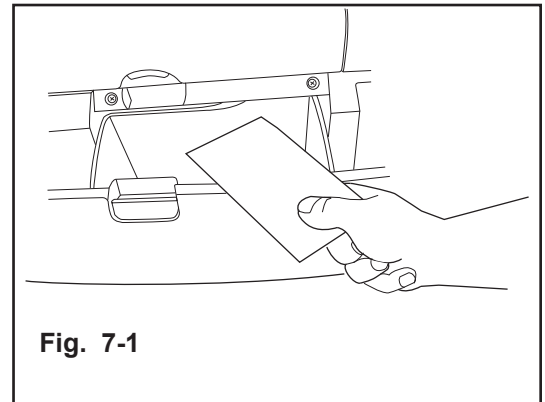

Fig. 7-1

## 8 Compass Zone Adjustment (Dealer Install ONLY)

6. Adjust compass zone after EC mirror installation.
  - a) The zone setting is factory preset to zone 8. Refer to Compass Calibration Zone Map (Fig. 8-1) to find the correct compass zone setting for your geographical location. Same map is in User Guide as well.
  - b) To change the zone setting, push and hold the right, compass display button until a number appears in the display. Press button repeatedly until desired compass zone number is reached.

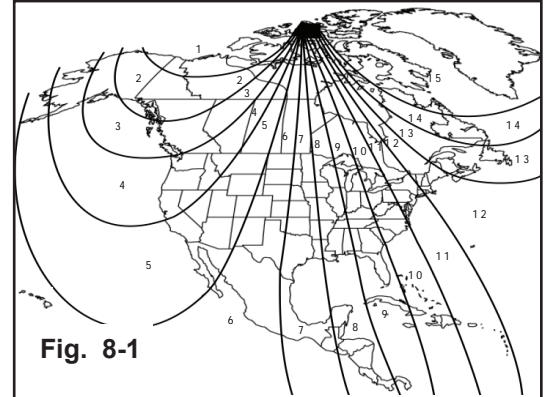

Fig. 8-1

## 9 Compass Calibration (Dealer Install ONLY)

7. Calibrate compass.
  - a) Drive to an open, level area, away from large metallic objects or structures.
  - b) Hold the right, compass display button for approximately 9 seconds, until "C" test appears in the display. Release the right button to enter the calibration mode.
  - c) Drive slowly in up to 3 circles until the "C" disappears and a directional heading is displayed. The compass is now calibrated.

## 10 Inspection

Inspection Parts	Inspection Items (O)			
	Clearance / Fit	Scratches / Dirt / Harness Interference	Installation / Tightening / Engagement	Operation Check
Negative battery terminal			O	
Driver-side Scuff Plate	O	O	O	
Driver-side Kick Plate	O	O	O	
Driver-side Door Seal	O	O	O	
Driver-side A-pillar Trim	O	O	O	
Drive-side visor clip	O	O	O	
EC mirror torx screw			*1	
EC harness connector			O	
EC mirror features:				
- auto-dimming				*2
- compass display				*3
User guide			*4	

**O : Applicable**

**\*1: Tightened to 15 lb-in (18 kg-cm)**

**\*2: Mirror dims (key must be in ON position).**

**\*3: Displays either "C" or directional heading (key must be in ON position).**

**\*4: In vehicle glove-box.**

### CAUTION



**When the battery is disconnected, the DSC may stop operating.**

(The DSC OFF indicator will flash at this time, and the TCS/DSC operation indicator will illuminate.)

Carry out the following procedure to reactivate DSC:

1. Turn the ignition switch to "OFF" and then turn it back to "ON".
2. Turn the steering wheel clockwise as far as it will go, and then turn it back counterclockwise as far as it will go.
3. Check that the TCS/DSC operation indicator is turned off.
4. Turn the ignition switch to "OFF" and then turn it back to "ON".
5. Check that the TCS/DCS operation indicator is turned off. If the TCS/DSC operation indicator is still illuminated or the DSC indicator is not turned off when the ignition switch is turned back to "ON", contact your Mazda dealer.

### CAUTION



**If the battery is disconnected, the power windows may no longer fully open or fully close automatically.**

Carry out the following operation at driver seat first and passenger seat to restore normal operation:

1. Turn the ignition key to the "ON" position.
2. Press the power window switch to fully open the power windows.
3. Lift up the power window switch to fully close the power windows, and keep it pulled up for approximately 2 seconds.
4. Position the engine switch at "OFF", and then at "ON" again. When the function doesn't work after these procedures, please contact your Mazda dealer.

## BASIC INSTALLATION TROUBLE-SHOOTING

**Verify the following:**

1. Switched harness wire (pin 6 terminal side) is receiving +12V with ignition ON and 0V with ignition OFF.
2. Ground wire(pin 3 terminal side) is securely attached.
3. Mirror harness is fully inserted into mirror.
4. Mirror harness is not pinched, cut or damaged.
5. Ensure IDC connectors are properly installed. Check to see that the blade in the connector did not miss either wire.

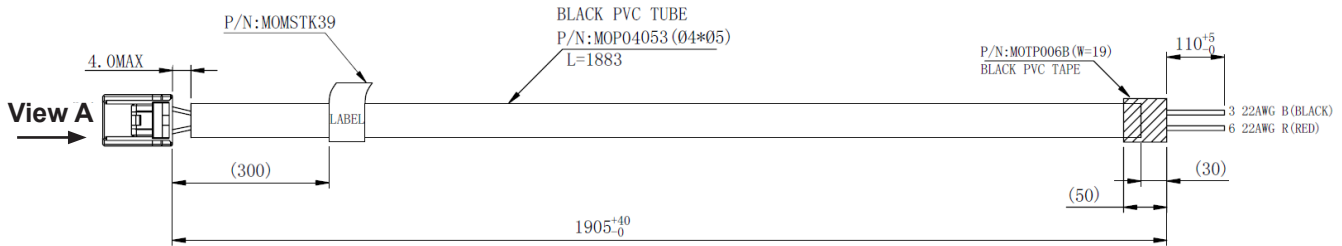

**View A (Terminal Side)**

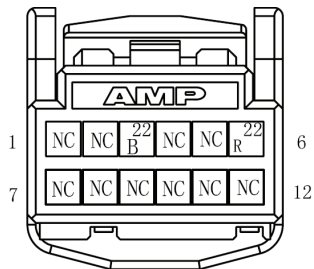

PIN	FUNCTION	NOTE	COLOR
1			
2			
3	GROUND		BLACK
4			
5	+12VDC SWITCHED	IGNITION	RED
6			
7			
8			
9			
10			
11			
12			